

SVILUPPO CARTONE IMPILABILE STACKED CARDBOARD DEVELOPMENT	L_{min}	200 mm ⁽²⁾	7 7/8" ⁽²⁾
	L_{max}	1040 mm ⁽²⁾	40 15/16" ⁽²⁾
	W_{min}	150 mm ⁽²⁾	5 29/32" ⁽²⁾
	W_{max}	740 mm ⁽²⁾	29 1/8" ⁽²⁾
VELOCITA' DI PRODUZIONE FINO A: PRODUCTION SPEED UP TO:		52 cicli/min ⁽²⁾	52 cycles/min ⁽²⁾
POTENZA ISTALLATA MC28/A – MC28/M INSTALLED POWER: MC28/A – MC28/M		3.8 kW - 3.5 kW	5.1 hp – 4.7 hp
PESO MC28/A – MC28/M WEIGHT: MC28/A – MC28/M		1850 kg – 1390 kg	4080 lb – 3065 lb
ALTEZZA LIMITE PILA MC28/A – MC28/M STACK HEIGHT LIMIT: MC28/A – MC28/M		1500 mm – 1700 mm ⁽³⁾	59 1/16" – 66 15/16" ⁽³⁾
CONSUMO MASSIMO ARIA COMPRESSA A 5 atm MAX. COMPRESSED AIR CONSUMPTION AT 5 atm		90 l/min	19,80 gal _{UK} /min 23,78 gal _{USA} /min 3,178 foot ³ /min

L'Impilatore MC28 viene installato al termine di una linea di accoppiatura MC2001/MESL–MC2001/MEWL ⁽¹⁾ o MC2000/MESL–MC2000/MEWL ⁽¹⁾ per accumulare prodotti in pila. Esiste in due versioni, entrambi dotate di sistema di scarico No-Stop:

The MC28 stacking machine is installed at the end of an MC2001/MESL–MC2001/MEWL ⁽¹⁾ or MC2000/MESL–MC2000/MEWL ⁽¹⁾ lamination production line to stack products in stacks. There are two versions, both equipped with a No-stop discharge system:

- MC28/A (è automatizzata la fase di carico pallet vuoto in macchina/scarico pallet pieno fuori macchina)
The MC28/A version (where the empty pallet loading phase in the machine/discharge full pallet out of the machine is automated).
- MC28/M (non è automatizzata la fase di carico pallet vuoto in macchina/scarico pallet pieno fuori macchina).
The MC28/M version (where the empty pallet loading phase in the machine/discharge full pallet out of the machine is not automated).

Le caratteristiche possono essere modificate senza preavviso. / The characteristics can be modified without prior notice.

- (1) Se accoppiato con una MC2000/MESL o MC2001/MESL l'impilatore deve essere preceduto da una calandra MC19 da ordinare separatamente. / If coupled with an MC2000/MESL or MC2001/MESL lamination production line, the stacking machine must be preceded by an MC19 calender that must be ordered separately.
- (2) La velocità di produzione massima ed i limiti di prodotto raggiungibili dipendono da diversi fattori tra cui la tipologia e le caratteristiche dei materiali usati (carta, cartone e collante), la formazione del personale addetto ed il formato del prodotto in lavorazione. / The maximum production speed and reachable product limits depend upon various factors such as the type and characteristics of materials used (paper, cardboard and glue), the training of the personnel and the format of the product being processed
- (3) L'altezza comprende anche il pallet. ⁽²⁾ / The height includes the pallet. ⁽²⁾

Vista dell'Impilatore MC28/A
View of the MC28/A stacking machine



Vista dell'Impilatore MC28/M
View of the MC28/M stacking machine



Layout e Ingombri
Layout and Overall

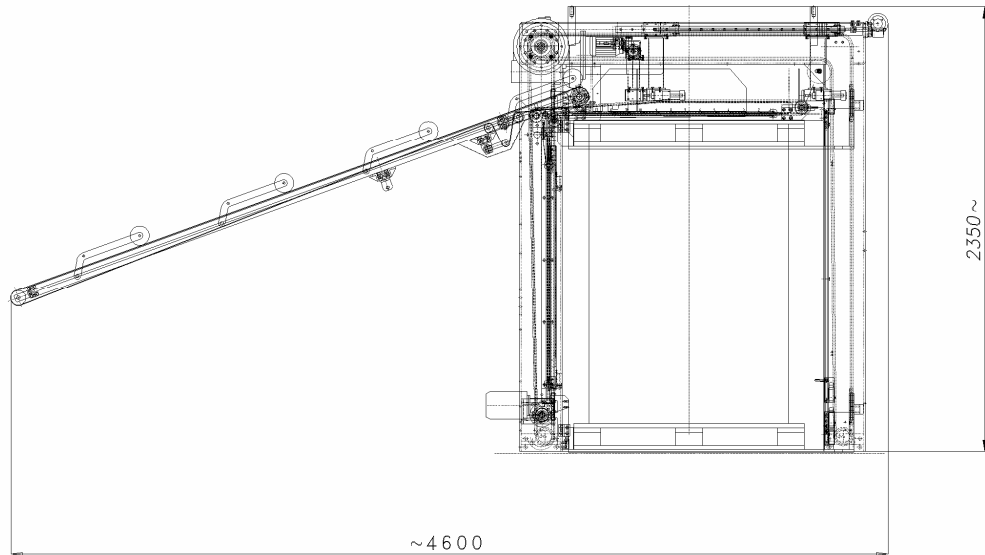

MC28/M

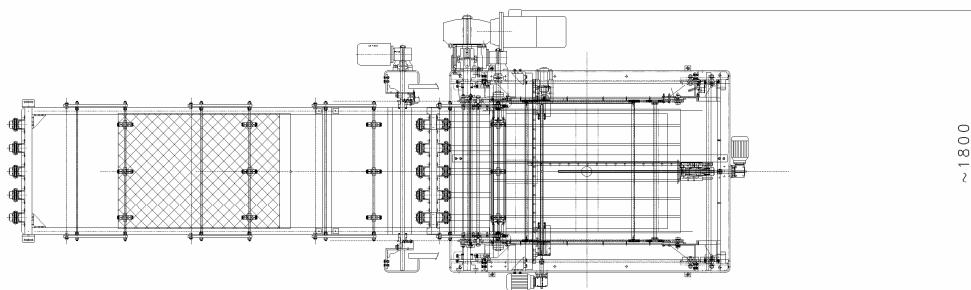

MC28/A

